

## Bench drills with continuously adjustable speed

### Convincing arguments: quality, efficiency and price

- Guaranteed concentricity precision less than 0.03 mm measured in the drilling spindle sleeve
- Drilling spindle with precision ball bearings
- High-grade quick-action drill chuck supplied as standard
- Smoother running due to aluminum pulleys with ground multitooth dog
- Higher power transmission due to the quality toothed V-belt
- Drill depth stop

**WALSHENGINEERING.COM**



Fig.: B 140 T Vario

Model	quantum B 140 T Vario	quantum B 160 T Vario
Item No	301 1714	301 1716
€ (VAT excl.)	<b>249.00</b>	<b>329.00</b>
<b>Features of performance</b>		
<b>Electrical connection</b>		
Motor	350 W 230 V ~50 Hz	600 W 230 V ~50 Hz
<b>Drilling capacity</b>		
Drilling capacity in steel	Ø 14 mm	Ø 16 mm
Working range	102 mm	126 mm
Sleeve travel	50 mm	60 mm
<b>Speeds</b>		
Spindle speed en	180 - 3,000 rpm	180 - 3,000 rpm
Number of steps	infinitely variable	infinitely variable
<b>Spindle holding fixture</b>		
Spindle holding fixture	B 16	MT 2
<b>Drilling table</b>		
Table size (L x W) extendable	190 x 170 (280) mm	240 x 200 (330) mm
Slot size table	14 mm	14 mm
Drilling table inclinable	45°	45°
Drilling table rotatable	360°	360°
Distance spindle - table (max.)	300 mm	400 mm
Working surface stand Length x Width	-	165 x 165 mm
T-slot size stand	-	16 mm
Distance spindle - stand (max.)	-	530 mm
<b>Dimensions</b>		
Upright diameter	50 mm	60 mm
Length	410 mm	520 mm
Width	240 mm	300 mm
Height	730 mm	850 mm
Net weight	30 kg	39.5 kg

### Extent of supply

- Quick-action drill chuck 0 - 13 mm
- Morse taper MT 2 - B 16 (B 160 T Vario)
- Drill chuck protection
- Machine lamp
- Drill bit box (empty)

### Accessories

#### Clamping tool kit SPW 12

Item No 335 2017

€ 79.- (VAT excl.)



#### Twist drill HSS

- With morse taper
- MT 2 (B160 T)

Item No 305 1002

€ 79.- (VAT excl.)



#### Titanium twist drill kit

- 25 pcs; 1 - 13 mm

Item No 305 1010

€ 28.- (VAT excl.)



More accessories from page 19 on

## B 140 T Vario B 160 T Vario

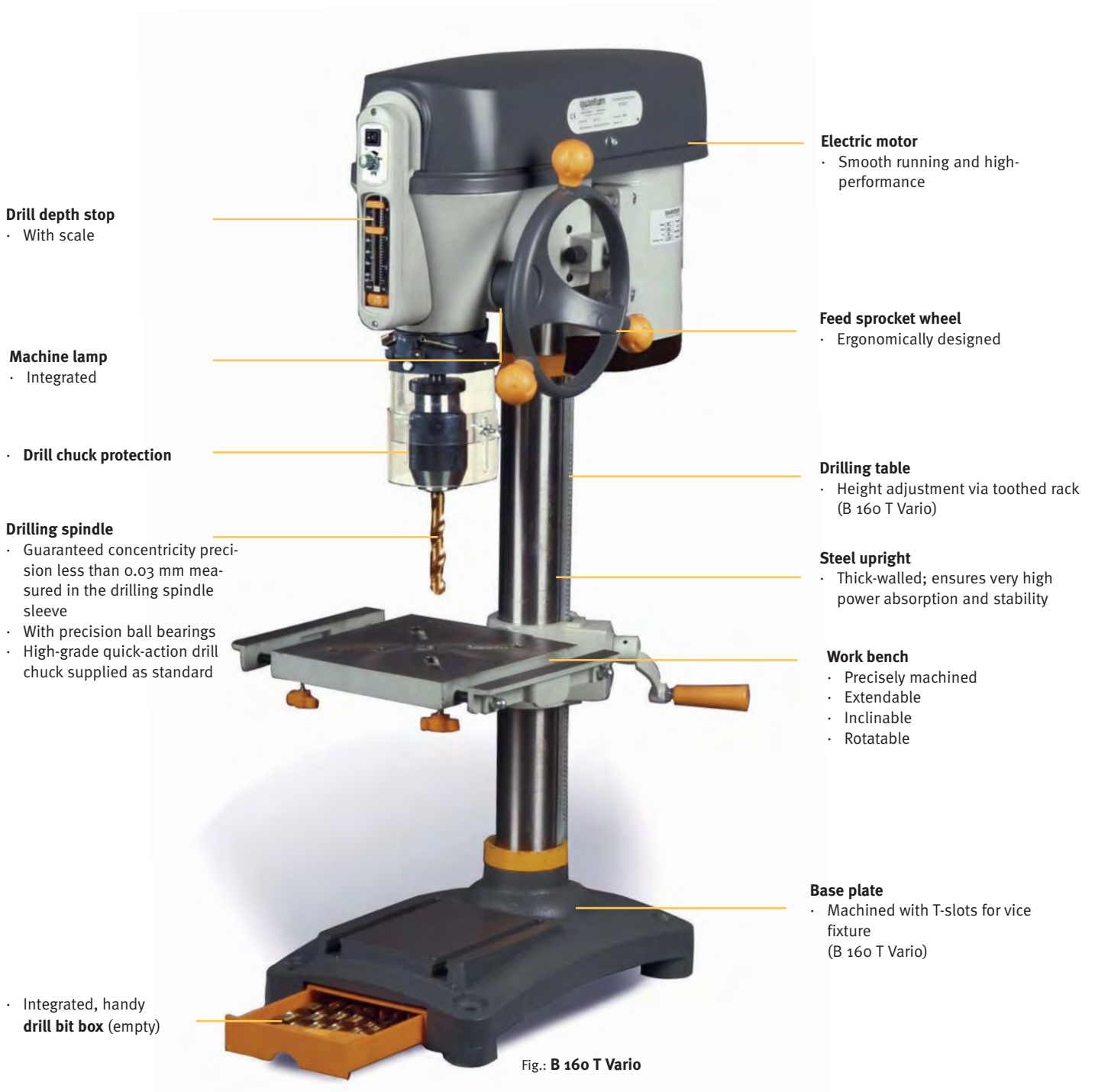

**Drill depth stop**  
· With scale

**Machine lamp**  
· Integrated

· **Drill chuck protection**

**Drilling spindle**  
· Guaranteed concentricity precision less than 0.03 mm measured in the drilling spindle sleeve  
· With precision ball bearings  
· High-grade quick-action drill chuck supplied as standard

· Integrated, handy **drill bit box** (empty)

**Electric motor**  
· Smooth running and high-performance

**Feed sprocket wheel**  
· Ergonomically designed

**Drilling table**  
· Height adjustment via toothed rack (B 160 T Vario)

**Steel upright**  
· Thick-walled; ensures very high power absorption and stability

**Work bench**  
· Precisely machined  
· Extendable  
· Inclined  
· Rotatable

**Base plate**  
· Machined with T-slots for vice fixture (B 160 T Vario)

Fig.: B 160 T Vario



· Better power transmission due to the **quality toothed V-belt**  
· Very smooth running due to **aluminum pulleys**



· Large **speed range**, continuously adjustable from 180 to 3000 rpm  
· Light switch