



**SOCIETÀ ITALIANA TECNOSPAZZOLE**

THE PROFESSIONAL CHOICE

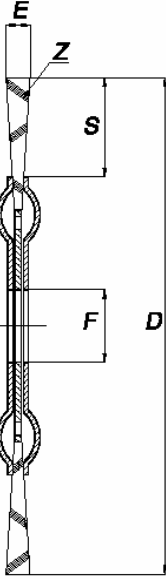

<b>Date: 07/10/2008</b> <b>Customer: WALSH ENGINEERING SUPPLIES LTD</b> <b>Customer's code: 974400</b>	<b>TECHINCAL PRODUCT DATA SHEET</b>
--	-------------------------------------

SIT Code	Item description	Brush Picture
U21A820A6000	901 REF U115 F22 IN050 12(BOX)  Twisted knots wheel brush Smooth bright stainless steel wire Ø 0.50	
<b>APPLICATIONS:</b> <ul style="list-style-type: none"> <li>aggressive brushes, suitable for heavy duty applications at high rotating speed, such as preparation and finishing of seam weldings, deburring and mechanical pickling.</li> <li>removal of slags collected inside narrow slots of any dimension.</li> <li>burrs removal.</li> </ul> <b>MAXIMUM ROTATING SPEED : 15000 RPM</b>		  D = 115 mm S = 25 mm F = 22,2 mm E = 12 mm Z = 20 Knots

**SAFETY INSTRUCTIONS:**

All the instructions enclosed to the brush box shall be strictly observed; in particular, but not only: never exceed MAX-RPM value; individual protective equipment must be worn such as goggles, gloves, face guard and shield, against particles ejection and e dangerous temperature onset; staff members without protections shall not allowed to stay around the worker, check brush locking on the electric tool and its maintenance onto the shaft; filaments should always work by tip, don't exceed with pressure, to be reduced at minimum when brushing sharp edges.

SPAZZOLE TECNICHE PER L'INDUSTRIA  
SPAZZOLE PER FERRAMENTA E UTENSILERIA  
SPAZZOLE PER AUTOSPAZZATRICI STRADALI E AEROPORTUALI  
PISTE IN PLASTICA PER SCI DI DISCESA, FONDO E SALTO



ASSOSPAZZOLE