



SOCIETÀ ITALIANA TECNOSPAZZOLE

THE PROFESSIONAL CHOICE



| | |
|--|-------------------------------------|
| Date: 07/10/2008 Customer: WALSH ENGINEERING SUPPLIES LTD Customer's code: 974400 | TECHINCAL PRODUCT DATA SHEET |
|--|-------------------------------------|

| SIT Code | Description | Brush Picture |
|--------------|--|---|
| U51883356000 | 519 REF U5181 F22 ATL 050C 8/32* Twisted knots wheel brush Smooth bright steel wire Ø 0.50 |  |

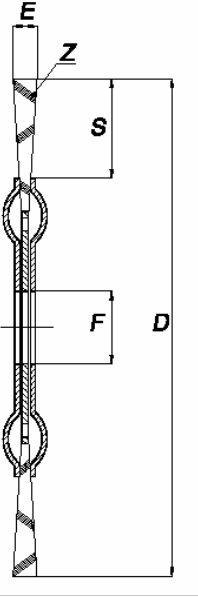
| | | |
|---|--|--|
| APPLICATIONS : <ul style="list-style-type: none"> aggressive brushes, suitable for heavy duty applications at high rotating speed, such as preparation and finishing of seam weldings, deburring and mechanical pickling. removal of slags collected inside narrow slots of any dimension. burrs removal. |  | D = 180 mm S = 32 mm F = 22,2 mm E = 11 mm Z = 32 knots |
| | | |

SAFETY INSTRUCTIONS:

All the instructions enclosed to the brush box shall be strictly observed; in particular, but not only: never exceed MAX-RPM value; individual protective equipment must be worn such as goggles, gloves, face guard and shield, against particles ejection and e dangerous temperature onset; staff members without protections shall not allowed to stay around the worker, check brush locking on the electric tool and its maintenance onto the shaft; filaments should always work by tip, don't exceed with pressure, to be reduced at minimum when brushing sharp edges.



ASSOSPAZZOLE

SPAZZOLE TECNICHE PER L'INDUSTRIA
SPAZZOLE PER FERRAMENTA E UTENSILERIA
SPAZZOLE PER AUTOSPAZZATRICI STRADALI E AEROPORTUALI
PISTE IN PLASTICA PER SCI DI DISCESA, FONDO E SALTO